

LCD MODULE SPECIFICATION

Customer: _____

Model Name: HP-320004-V1

Date: 2018-06-10

Version: 1.0

Approved by	Reviewed by	Prepared by

For Customer's Acceptance

Approved by	Comment

Contents

1. General Specifications.....	1
2. Pin Assignments.....	2
3. Electrical Specifications.....	3
3.1. Absolute Maximum Rating.....	3
3.2. Typical Operation Conditions.....	3
3.3. Backlight Unit.....	5
4. Optical Specifications.....	5
5. Reliability Test Items.....	10
6. Handling Precautions.....	11
6.1. Safety.....	11
6.2. Handling.....	11
6.3. Static Electricity.....	11
6.4. Storage.....	11
6.5. Cleaning.....	11
7. Mechanical Drawing.....	12
8. Package Drawing.....	13

1. General Specifications

No.	Item	Specification	Unit	Remark
1	LCD Size	3.2"	inch	-
2	Panel Type	a-si TFT	-	-
3	Resolution	240x(RGB)x320	pixel	-
4	Display Mode	Normally white, Transmissive	-	-
5	Display Number of Colors	262K	-	-
6	Viewing Direction	12 o'clock	-	Note 1
7	Contrast Ratio	300	-	-
8	Luminance	250	cd/m ²	
9	Module Size	54.34(W)x77.70(L)x2.3 (T)	mm	Note 1
12	Weight	TBD	g	-
13	Driver IC	ILI9341V	-	-
14	Driver IC RAM Size	240x16x320	bit	-
15	Light Source	6 LEDs in Parallel	-	-
16	Interface	MCU Interface 8/16bit	-	-
17	Operating Temperature	-20~70		-
18	Storage Temperature	-30~80		-

Note 1: Please refer to the mechanical drawing.

2. Pin Assignments

Pin No.	Symbol	I/O	Function	Remark
1	NC	/	NC	-
2	GND	P	Power Ground	-
3	NC	/	NC	-
4	LEDA	P	LED+	-
5	LEDK1	P	LED-	-
~	~	P	LED-	-
10	LEDK6	P	LED-	-
11	NC	/	NC	-
12	NC	/	NC	-
13	NC	/	NC	-
14	GND	P	Power Ground	-
15	RESET	I	Resetsignal , active low	-
16	NC	/	NC	-
17	D15	I/O	DATA BUS H8 bit	-
~	~	I/O	DATA BUS H8 bit	-
24	D8	I/O	DATA BUS H8 bit	-
25	NC	/	NC	-
26	D7	I/O	DATA BUS L8 bit	-
~	~	I/O	DATA BUS L8 bit	-
33	D0	I/O	DATA BUS L8 bit	-
34	GND	P	Power Ground	-
35	NRD	I	Read Enable Signal	-
36	NWR	I	Write Enable Signal	-
37	RS	I	Command/Data Select	-
38	NCS	I	Chip Select	-
39	NC	/	NC	-
40	VCI	P	Power supply (2.8V~3.3V)	-
41	IOVCC	P	Power supply (1.8V/2.8V~3.3V)	-
42	NC	/	NC	-
43	NC	/	NC	-
44	NC	/	NC	-
45	NC	/	NC	-
46	NC	/	NC	-

3. Electrical Specifications

3.1. Absolute Maximum Rating

(T_a=+25)

Item	Symbol	Values		Unit	Remark	
		Min.	Max.			
TFT Module	I/O Circuit Supply Voltage	VDD	-0.3	4.6	V	Note 1
	Analog/Logic Supply Voltage	VCI	-0.3	4.6	V	Note 1
Backlight Unit	Current	I _B	-	150	mA	Note 2
	Power Consumption	P _{BL}	-	480	mW	Note 2

Note1: Permanent damage to the device may occur if maximum values are exceeded or reverse voltage is applied.

Note2: Without LED driver IC, please refer to 2.4.

3.2. Typical Operation Conditions

3.2.1 DC Characteristics

(T_a=+25 , VCI=+2.8V)

Item	Symbol	Values			Unit	Remark
		Min.	Typ.	Max.		
Logic Supply Voltage	VDD	2.6	2.8	3.3	V	Ta=25
Analog Supply Voltage	VCI	2.6	2.8	3.3	V	
Input High Voltage	V _{IH}	0.7VDD	-	VDD	V	
Input Low Voltage	V _{IL}	0	-	0.3VDD	V	
Output High Voltage	V _{OH}	0.8VDD	-	VDD	V	
Output Low Voltage	V _{OL}	0	-	0.2VDD	V	
Frame Frequency	f _{FRAME}	-	65	-	Hz	

Note: To prevent IC latch up or DC operation in LCD panel, the power on/off sequence should follow the driver IC specification.

3.2.2 Current Consumption

Item	Symbol	Values		Unit	Remark
		Typ.	Max.		
MCU Interfscce (8080 16-bit parallel Interface)					
Still Mode	VDD	-	TBD	uA	Note1
	VCI	-	TBD	mA	
Sleep Mode	VDD	-	TBD	uA	Note1, Note3
	VCI	-	TBD	uA	

Note1: Test Condition

Typ: VDD=2.8V

Max: VDD=3.0V

VCI=2.8V

Display Pattern: 8 Color Bar

Frame Rate=80Hz at Line Inversion

Operating Temperature: 25

VCI=3.3V

Display: Pattern:All Pixel Black

Frame Rate=80Hz at Line Inversion

Operating Temperature: 25

Typ. current check pattern:

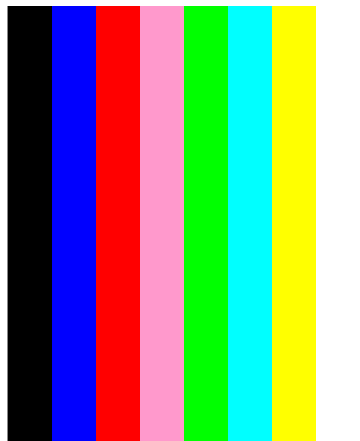

8-Color Bar

Max. current check pattern:

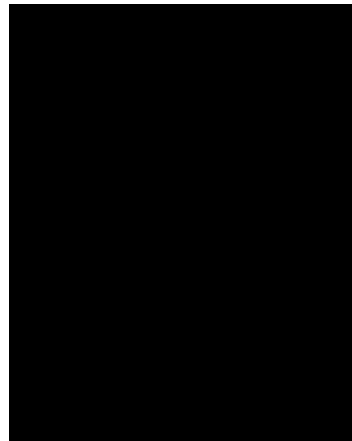

Black

Note2: In the standby mode, all the internal display operations are suspended including the internal R-C oscillator.

Note3: In the sleep mode, all the internal display operations are suspended except the internal R-C oscillator.

3.3. Backlight Unit

The backlight system is an edge lighting type with 4 white LEDs.

($T_a=+25$)

Item	Symbol	Values			Unit	Remark
		Min.	Typ.	Max.		
Current	I_B	-	120	-	mA	Note 1
Power Consumption	P_{BL}	-	384	-	mW	Note 2

Note1: 4 LEDs are connected in parallel; each LED's current consumption is 20mA.

Note2: Where $I_B= 120$ mA, $P_{BL} = I_B \times V_{BL}$, V_{BL} is backlight forward voltage.

4. Optical Specifications

($T_a=+25$, $V_{CI}=2.8V$, $V_{DD}=1.8V$, $I_B=46mA$)

Item	Symbol	Condition	Values			Unit	Remark	
			Min.	Typ.	Max.			
Viewing Angle Range	Left	L	CR 10	-	50	-	degree	Note 1,2
	Right	R		-	50	-		
	Top	T		-	20	-		
	Bottom	B		-	50	-		
Response Time	$T_{on} + T_{off}$	Normal = $\approx 0^\circ$	-	30	50	ms	Note 2,3	
Contrast Ratio	CR	Normal = $\approx 0^\circ$	250	300	-	-	Note 2,4	
Luminance	L	Normal = $\approx 0^\circ$	200	250	-	cd/m ²	Note 2,5	
Flicker	-	-	No Visible			-	Note 8	
Crosstalk	-	-	No Visible			-	Note 9	
Color Chromaticity (CIE1931)	White	W_x	Normal = $\approx 0^\circ$	-	0.30	-	-	Note 2,6
		W_y		-	0.31	-		
	Red	R_x		-	0.59	-		
		R_y		-	0.32	-		
	Green	G_x		-	0.31	-		
		G_y		-	0.56	-		
	Blue	B_x		-	0.15	-		
		B_y		-	0.08	-		
Color Gamut	NTSC	CIE1931	-	58	-	%	-	
Luminance Uniformity	U_L	Normal = $\approx 0^\circ$	-	80	-	%	Note 2,7	

Note 1: Definition of viewing angle

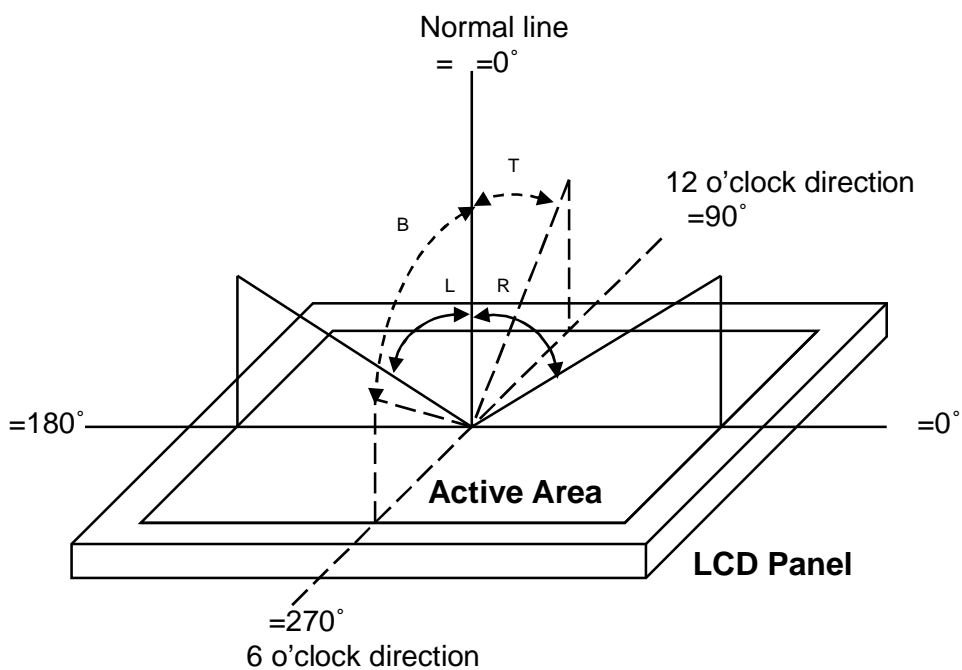

range

Fig. 1 Definition of viewing angle

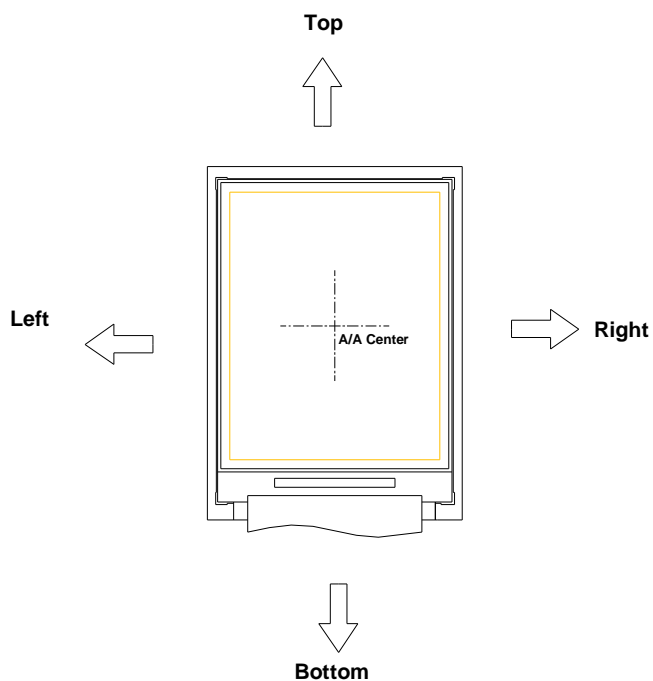

Fig. 2 Definition of viewing angle for display

Note 2: Definition of optical measurement system

The optical characteristics should be measured in a dark room with ambient temperature $T_a=+25$. The optical properties are measured at the center point of the LCD screen after 5 minutes operation. (Equipment: Photo detector TOPCON BM-5A or BM-7 /Field of view: 1° /Height: 500mm.)

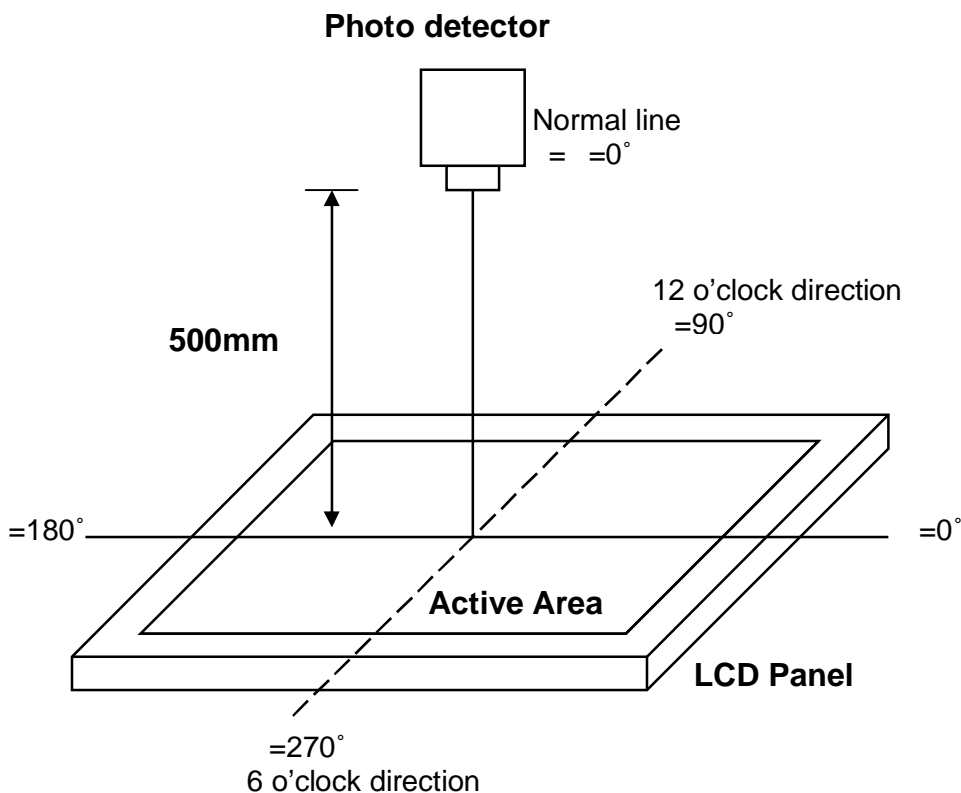

Fig. 3 Optical measurement system setup

Note 3: Definition of response time

The response time is defined as the LCD optical switching time interval between "White" state and "Black" state. Rise time (T_{on}) is the time between photo detector output intensity changed from 90% to 10%, and fall time (T_{off}) is the time between photo detector output intensity changed from 10% to 90%.

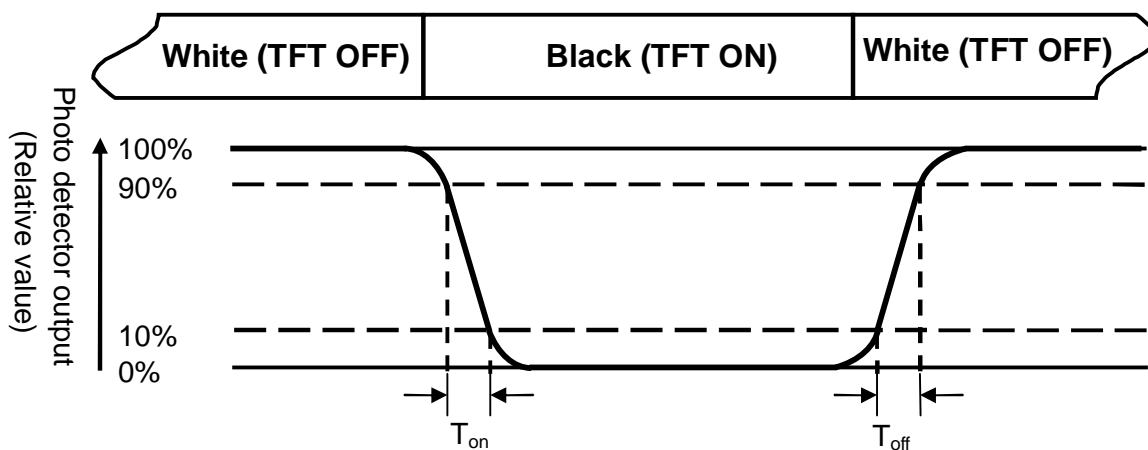

Fig. 4 Definition of response time

Note 4: Definition of contrast ratio

$$\text{Contrast ratio (CR)} = \frac{\text{Luminance measured when LCD on the "White" state}}{\text{Luminance measured when LCD on the "Black" state}}$$

Note 5: Definition of luminance

Measured at the center area of the panel when LCD panel is driven at "white" state.

Note 6: Definition of color chromaticity (CIE1931)

Color coordinates measured at the center point of LCD when panel is driven at "White", "Red", "Green" and "Blue" state respectively.

Note 7: Definition of luminance uniformity

To test for uniformity, the tested area is divided into 3 rows and 3 columns. The measurement spot is placed at the center of each circle as below.

$$\text{Luminance Uniformity (U}_L\text{)} = \frac{L_{\min}}{L_{\max}}$$

L-----Active area length W----- Active area width

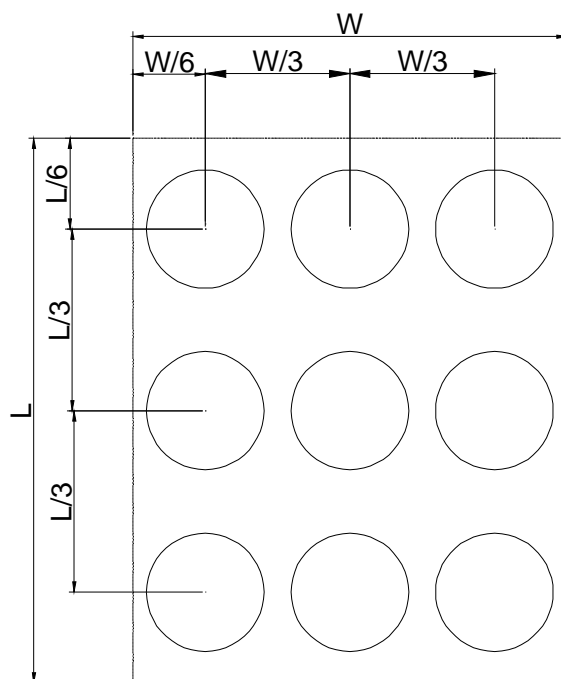

Fig. 5 Definition of luminance uniformity

L_{\max} : The measured maximum luminance of all measurement position.

L_{\min} : The measured minimum luminance of all measurement position.

Note 8: Definition of Flicker

Flicker is the pattern usually used to describe the visual sensation produced by a rapidly varying light intensity. There should be no visible flicker in normal direction of the display when the following figure are loaded.

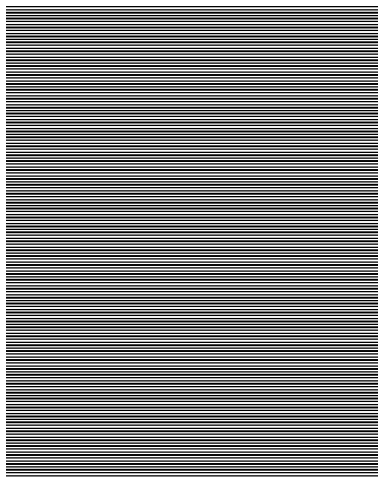

Fig.6 Flicker checker pattern

Note9: Definition of crosstalk

There should be no visible in normal direction of the display when the following figures are loaded.

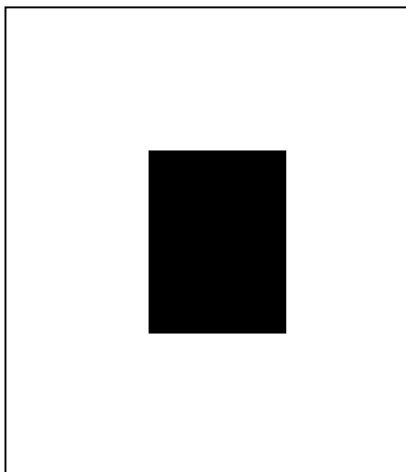

Fig.7 Crosstalk checker pattern

5. Reliability Test Items

Test Items	Test Conditions	Remark
High Temperature Storage	+80 ±3 for 240 hours	-
Low Temperature Storage	-30 ±3 for 240 hours	-
High Temperature Operation	+70 ±3 for 240 hours	-
Low Temperature Operation	-20 ±3 for 240 hours	-
High Temperature and Humidity Operation	+60 ±3 , 90%±3%RH max. for 240 hours	-
Thermal Shock	-30 /0.5h ~ +80 /0.5h for a total 100 cycles, Start with cold temp and end with high temp	-
Vibration Test	Frequency range:10~55Hz Stoke:1.5mm Sweep:10Hz~55Hz~10Hz 2 hours for each direction of X. Y. Z. (6 hours for total)	-
Mechanical Shock	100G 6ms,±X, ±Y, ±Z 3 times for each direction	-
Package Vibration Test	Random Vibration : 0.015G ² /Hz from 5-200Hz, -6dB/Octave from 200-500Hz 1 hour for each direction of X. Y. Z. (3 hours for total)	-
Package Drop Test	Height :76cm(Weight 10kg); 60cm(Weight>10kg) 1 corner, 3 edges, 6 surfaces	-
Electro Static Discharge	± 2KV, Human Body Mode, 100pF/1500	-

Note1: During the display practical test under normal operation condition, there shall be no change, which may affect display function.

Note2: Before functional check, the test sample requires a 2 hours storage time at room temperature.

6. Handling Precautions

6.1. Safety

- 6.1.1. The liquid crystal in the LCD is poisonous. DO NOT put it in your mouth. If the liquid crystal touches your skin or clothes, wash it off immediately using soap and water.**

6.2. Handling

- 6.2.1. The LCD and touch panel is made of plate glass. DO NOT subject the panel to mechanical shock or to excessive force on its surface.**
- 6.2.2. Do not handle the product by holding the flexible pattern portion in order to assure the reliability**
- 6.2.3. Transparency is an important factor for the touch panel. Please wear clear finger sacks, gloves and mask to protect the touch panel from finger print or stain and also hold the portion outside the view area when handling the touch panel.**
- 6.2.4. Provide a space so that the panel does not come into contact with other components.**
- 6.2.5. To protect the product from external force, put a covering lens (acrylic board or similar board) and keep an appropriate gap between them.**
- 6.2.6. Transparent electrodes may be disconnected if the panel is used under environmental conditions where dew condensation occurs.**
- 6.2.7. Property of semiconductor devices may be affected when they are exposed to light, possibly resulting in IC malfunctions.**
- 6.2.8. To prevent such IC malfunctions, your design and mounting layout shall be done in the way that the IC is not exposed to light in actual use.**

6.3. Static Electricity

- 6.3.1. Ground soldering iron tips, tools and testers when they are in operation.**
- 6.3.2. Ground your body when handling the products.**
- 6.3.3. Power on the LCD module BEFORE applying the voltage to the input terminals.**
- 6.3.4. DO NOT apply voltage which exceeds the absolute maximum rating.**
- 6.3.5. Store the products in an anti-electrostatic bag or container.**

6.4. Storage

- 6.4.1. Store the products in a dark place at +25 ±10 with low humidity (65%RH or less).**
- 6.4.2. DO NOT store the products in an atmosphere containing organic solvents or corrosive gas.**

6.5. Cleaning

- 6.5.1. DO NOT wipe the touch panel with dry cloth, as it may cause scratch.**
- 6.5.2. Wipe off the stain on the product by using soft cloth moistened with ethanol. DO Not allow ethanol to get in between the upper film and the bottom glass. It may cause peeling issue or defective operation. Do not use any organic solvent or detergent other than ethanol.**

7. Mechanical Drawing

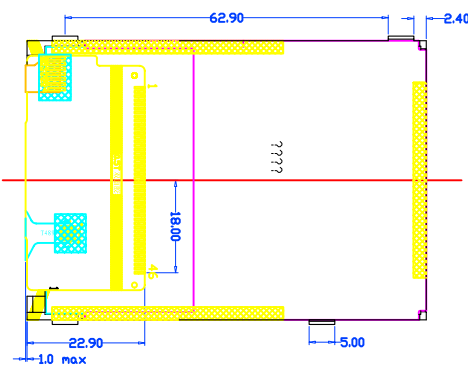
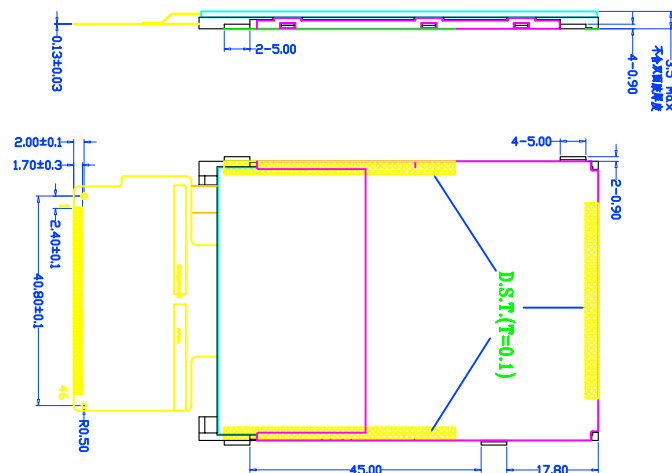
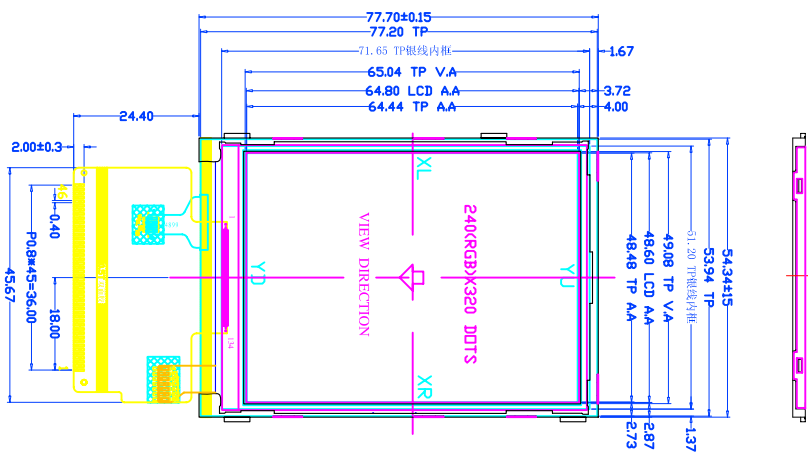

1	NC
2	GND
3	INVERSE BIT
4	LED-A
5	LED-K1
6	LED-K2
7	LED-K3
8	LED-K4
9	LED-K5
10	LED-K6
11	NC
12	NC
13	NC
14	GND
15	INVERSE
16	NC
17	DB15
18	DB14
19	DB13
20	DB12
21	DB11
22	DB10
23	DB9
24	DB8
25	NC
26	DB7
27	DB6
28	DB5
29	DB4
30	DB3
31	DB2
32	DB1
33	DB0
34	GND
35	NRD
36	NWR
37	RS
38	NCS
39	NC
40	VCI
41	VCC
42	NCVDD
43	NCVDD
44	NCVDD
45	NCVDD
46	LCM_ID

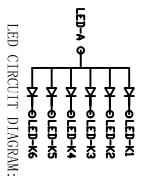

Pin ID	Assignment
1	VCI
2	VCC
3	YD
4	XR

逻辑图

- Specification:
- (1) Viewing angle: 12 O'clock
 - (2) Display mode: 262K TFT/Normally White/Transmissive
 - (3) Operating temp.: -20°C~+70°C
 - (4) Storage temp.: -30°C~+80°C
 - (5) IC: GC9302
 - (6) Backlight: 6 chip White LED, in Parallel Vr:3.2 V If:90 mA
 - (7) Dimensions with mark "*" are important, with mark "()" are referenced
- (7). Request ROHS

DRAWN BY:	JACK	2013.06.08	SCALE:	1:1	MATERIAL:	-
CHECK BY:			UNIT:	mm	TOLERANCE:	±0.2
APPROVER:			PAGE:	1 of 1		